

NJCAT TECHNOLOGY VERIFICATION

BioPod™ Biofilter with StormMix Media™

Oldcastle Precast Inc.

May 2018

Table of Contents

Table of Contents	i
List of Figures	ii
List of Tables	iii
1. Description of Technology	1
2. Laboratory TestingTes	3
2.1 Test Setup.....	3
2.2 Test Sediment.....	6
2.3 Removal Efficiency Testing.....	8
2.4 Sediment Mass Loading Capacity Testing.....	9
2.5 Scour Testing.....	9
3. Performance Claims.....	10
4. Supporting Documentation	11
4.1 Removal Efficiency.....	11
4.2 Sediment Mass Loading Capacity.....	17
4.3 Filter Driving Head	22
5. Design Limitations.....	23
6. Maintenance Plans	25
7. Statements.....	28
8. References.....	34
Verification Appendix	35

List of Figures

	Page
Figure 1 BioPod™ Biofilter.....	2
Figure 2 Test Flow Loop Layout	3
Figure 3 Photograph of Test Flow Loop.....	4
Figure 4 Gutter Tray	4
Figure 5 BioPod™ Biofilter Effluent Pipe	5
Figure 6 Background Sampling Point.....	6
Figure 7 Average Particle Size Distribution of Test Sediment.....	7
Figure 8 Sediment Sampling Point	8
Figure 9 Removal Efficiency vs Sediment Mass Loading for the BioPod™ Biofilter	17
Figure 10 Increase in Driving Head vs Sediment Mass Load	23

List of Tables

	Page
Table 1 Standard Precast BioPod™ Biofilter Configurations	2
Table 2 Particle Size Distribution of Test Sediment.....	7
Table 3 Removal Efficiency Sampling Frequency	9
Table 4 Removal Efficiency Water Flow Rate	12
Table 5 Removal Efficiency Sediment Feed Rate	13
Table 6 Removal Efficiency Drain Down Losses.....	14
Table 7 Removal Efficiency SSC Data.....	15
Table 8 Removal Efficiency Results.....	16
Table 9 Sediment Mass Loading Water Flow Rate	18
Table 10 Sediment Mass Loading Sediment Feed Rate	19
Table 11 Sediment Mass Loading Drain Down Losses.....	20
Table 12 Sediment Mass Loading SSC Data.....	21
Table 13 Sediment Mass Loading Removal Efficiency Results.....	22
Table A-1 BioPod™ Biofilter Model Sizes and New Jersey Treatment Capacities	37

1. Description of Technology

The BioPod™ Biofilter (BioPod™) system with StormMix™ filter media is a stormwater biofiltration treatment system that uses physical, chemical and biological treatment processes such as filtration, sorption, and biological uptake to remove total suspended solids (TSS), metals, nutrients, gross solids, trash and debris, and petroleum hydrocarbons from stormwater runoff. The BioPod™ system uses engineered, high flow rate StormMix filter media to remove stormwater pollutants, allowing for a smaller footprint than conventional bioretention systems. Within a compact precast concrete vault, the BioPod™ system consists of a biofiltration chamber and an optional integrated high-flow bypass with a contoured inlet rack to minimize scour. The biofiltration chamber is filled with layers of aggregate (which may or may not include an underdrain), StormMix biofiltration media, and mulch.

The BioPod™ system can be configured with either an internal or external bypass. The internal bypass allows both water quality flows and bypass flows to enter the system. The water quality flows are directed to the biofiltration chamber and the excess flows are diverted over the bypass weir without entering the biofiltration chamber. Both the treatment flows and bypass flows are combined in the outlet area prior to discharge out of the system. BioPod™ units without an internal bypass are designed such that only treatment flows enter the system. When the system has exceeded its treatment capacity, additional flows will continue down the gutter to the nearest external bypass structure. This bypass structure may be, but is not limited to, a storm drain inlet, pond, detention structure or swale located downstream of the BioPod™.

The BioPod™ system can be configured as a tree box filter with tree and grated inlet, as a planter box filter with shrubs, grasses and an open top, or as an underground filter with access risers, doors and a subsurface inlet pipe. In addition, an open bottom configuration is available, to promote infiltration and groundwater recharge. The configuration and size of the BioPod™ system can be designed to meet the specific requirements of each individual project. The BioPod™ sizes are listed in **Table 1**. The configuration of the standard BioPod™ system is shown in **Figure 1**.

As with any stormwater treatment system, the BioPod™ requires regular maintenance to prolong the life of the system. Periodic maintenance includes removal of gross pollutants from the biofiltration chamber and removal and replacement of the mulch layer as needed. Frequency of maintenance depends on the conditions of the site and performance of the system.

Table 1 Standard Precast BioPod™ Biofilter Configurations

Length (feet)	Width (feet)	Media Surface Area (square feet)	Flow Rate (gallons/minute)
4	4	16	28.8
6	4	24	43.2
8	4	32	57.6
12	4	48	86.4
6	6	36	64.8
8	6	48	86.4
12	6	72	129.6
16	8	128	230.4

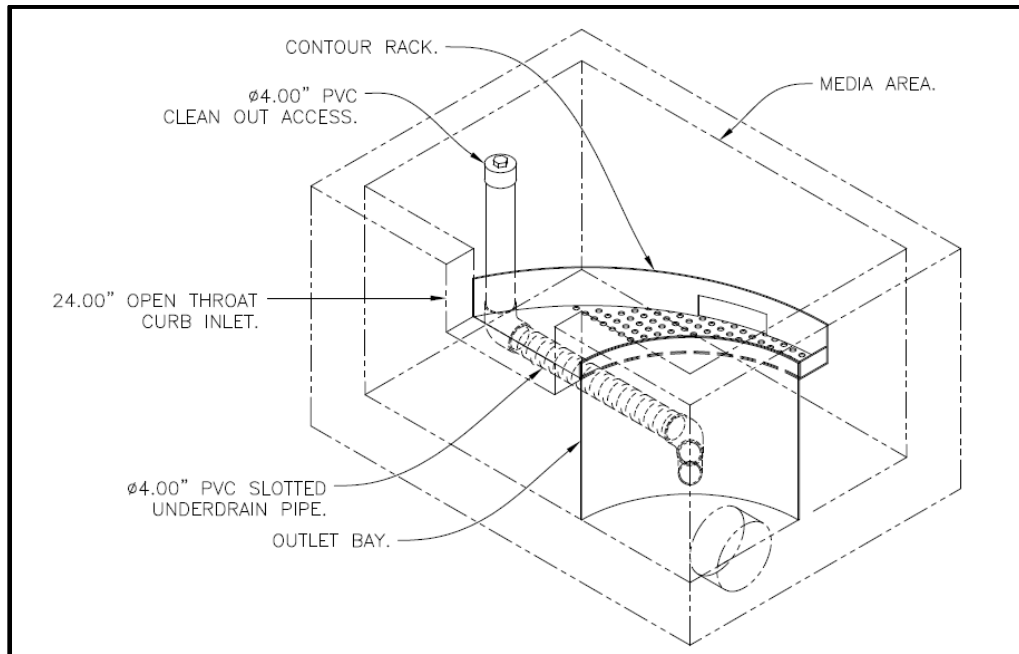

Figure 1 BioPod™ Biofilter

2. Laboratory Testing

The test program was conducted by Good Harbour Laboratories, an independent water technology testing lab, at their site in Mississauga, Ontario. Testing occurred during the month of October 2017. The BioPod™ Biofilter system that was tested in the laboratory consisted of a standard biofiltration chamber and inlet contour rack with bypass weir, in a 4-foot by 6-foot vault made of plywood. In commercial systems, the internal components are typically housed in a concrete vault. For this testing however, the use of a plywood vault was proposed due to the difficulties associated with transporting and physically supporting the weight of a concrete vault. The plywood vault of the test unit was equivalent to commercial concrete vaults in all key dimensions. The use of the plywood vault in lieu of concrete did not have an impact on system performance. Additionally, the test unit did not have a concrete top that would be associated with a unit installed below grade. For lab testing there was no need for a concrete top as it would inhibit access to the unit. There was no effect on testing by not having a top on the unit. In order to mimic a roadway gutter line and direct influent flow to the unit, the test system was configured with a manufactured gutter tray, fitted to the outside of the test unit.

Laboratory testing was done in accordance with the *New Jersey Department of Environmental Protection Laboratory Protocol to Assess Total Suspended Solids Removal by a Filtration Manufactured Treatment Device (January 2013b)*. Prior to starting the performance testing program, a quality assurance project plan (QAPP) was submitted to and approved by the New Jersey Corporation for Advanced Technology (NJCAT).

2.1 Test Setup

The laboratory test setup was a water flow loop filled with potable water. The loop was comprised of storage tanks, pumps, receiving tank and flow meters, in addition to the BioPod™ Biofilter. The test flow loop layout is illustrated in **Figure 2** and shown in **Figure 3**.

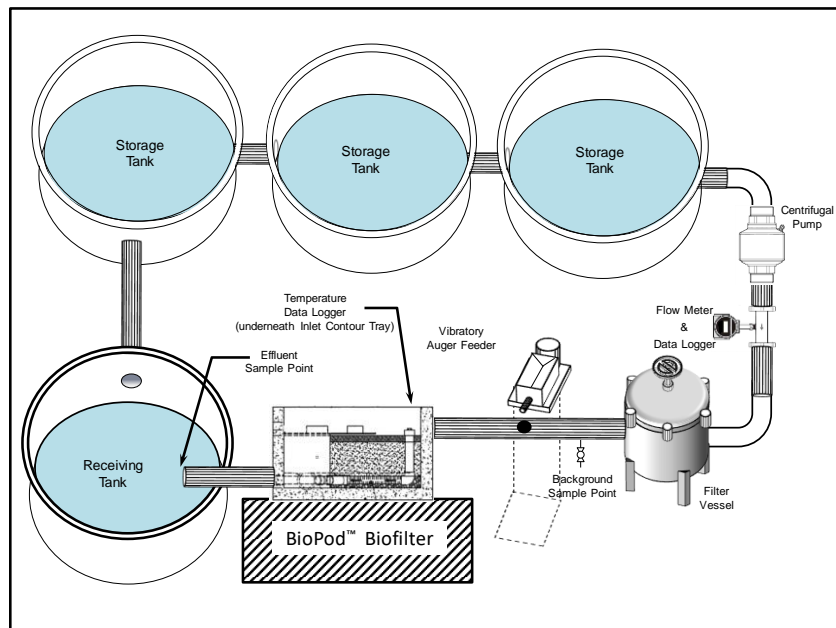

Figure 2 Test Flow Loop Layout



Figure 3 Photograph of Test Flow Loop

Water Flow and Measurement

From the storage tanks, water was pumped using a WEG Model FC00312 centrifugal pump through a 3" PVC line that transitioned to 8" prior to the sediment addition point. Flow was measured using a Toshiba Model GF630 mag-type flow meter and recorded using a MadgeTech Process 101A data logger. The data logger recorded a flow measurement once every minute.

The water in the flow loop was circulated through a filter vessel containing high-efficiency pleated bag filters with a 0.5 μm absolute rating. The filter was a sealed vessel that always maintained a constant volume.

The influent pipe discharged onto a gutter tray to mimic the flow of water as it would enter the BioPod™ Biofilter in a roadway application (**Figure 4**).



Figure 4 Gutter Tray

Water flow exited the BioPod™ Biofilter through a 4" effluent pipe that terminated with a free-fall into the Receiving Tank (**Figure 5**) to complete the flow loop.



Figure 5 BioPod™ Biofilter Effluent Pipe

Water Sample Collection

Background water samples were collected in 1L jars from a sampling port located upstream of the auger feeder, and downstream of the sediment filtration system. The sampling port was controlled manually by a ball valve (**Figure 6**) that was opened approximately 5 seconds prior to sampling.

Effluent samples were also grabbed by hand. The sampling technique took the grab sample by holding a wide-mouth 1 L jar at the narrowest point of the effluent stream flow, until the jar was full.

Other Instrumentation and Measurement

Water temperature was taken during each run using a MadgeTech MicroTemp data logger that was placed underneath the contour rack of the BioPod™ Biofilter. The Micro Temp was configured to take a temperature reading once every minute.

To allow for system head loss measurements, a 4" diameter perforated stand-pipe was added to the corner furthest from the bypass chamber. The standpipe was capped at the bottom, set on top of the vault floor and was wrapped in a geotextile to minimize sediment infiltration through the perforations.

The water level was measured from the base of the stand-pipe with a gauge stick and recorded at five-minute intervals. The tolerance of the gauge for head loss measurements was $\pm 0.125''$.

Run and sampling times were measured using a stopwatch (Control Company Model X4C50200C).



Figure 6 Background Sampling Point

2.2 Test Sediment

The test sediment used for the removal efficiency study was custom blended by GHL using various commercially available silica sands; this particular batch was GHL lot # A017-091. Three samples of sediment were sent out for particle size analysis using the methodology of ASTM method D422-63. The samples were composite samples created by taking samples throughout the blending process and in various positions within the blending drum. The testing lab was Maxxam Analytics, an independent test lab also located in Mississauga, Ontario Canada. The PSD results are summarized **Table 2** and shown graphically in **Figure 7**.

Table 2 Particle Size Distribution of Test Sediment

Particle Size (Microns)	Test Sediment Particle Size (% Less Than) [◇]				NJDEP Minimum Specification* (% Less Than)	QA/QC
	Sample 1	Sample 2	Sample 3	Average		
1000	100	100	100	100	100	PASS
500	98	98	98	98	95	PASS
250	90	91	90	90	90	PASS
150	80	80	80	80	75	PASS
100	60	59	59	59	60	PASS
75	52	52	52	52	50	PASS
50	45	45	45	45	45	PASS
20	37	38	37	37	35	PASS
8	21	20	19	20	20	PASS
5	13	13	12	13	10	PASS
2	6	5	6	6	5	PASS
d ₅₀	68 μm	69 μm	69 μm	69 μm	≤ 75 μm	PASS

[◇] Where required, particle size data has been interpolated to allow for comparison to the required particle size specification.

* A measured value may be lower than a target minimum % less than value by up to two percentage points provided the measured d₅₀ value does not exceed 75 microns.

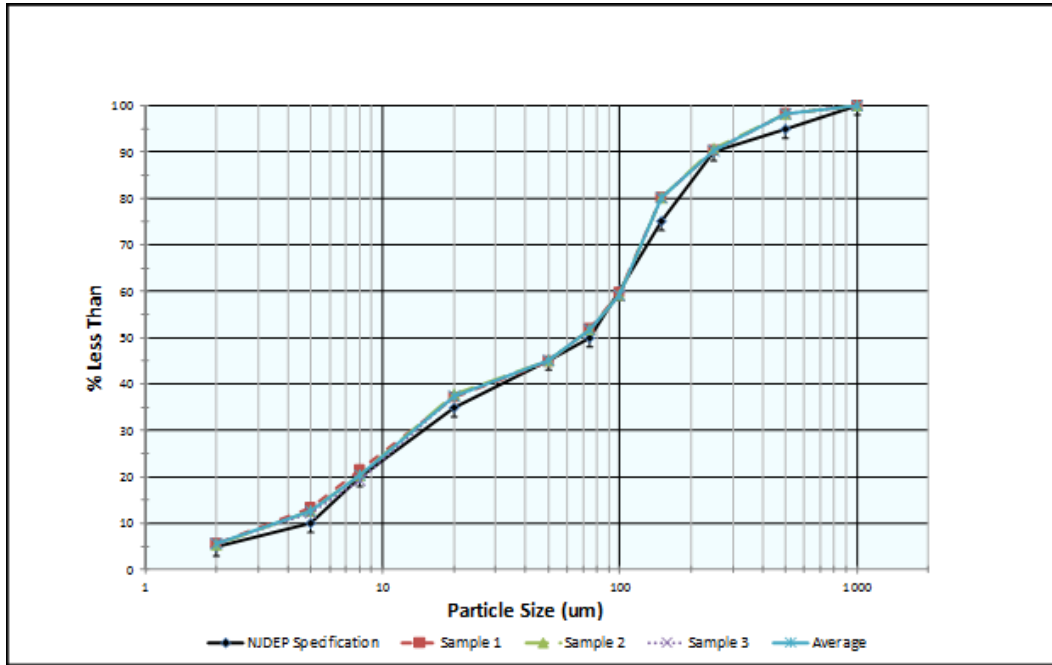

Figure 7 Average Particle Size Distribution of Test Sediment

In addition to particle size distribution, Maxxam Analytics also performed a moisture analysis of the test sediment and determined the water content to be < 0.30%, the method detection limit.

The blended test sediment was found to meet the NJDEP particle size specification and was acceptable for use. With a d_{50} of 69 μm , the test sediment was slightly finer than the sediment required by the NJDEP test protocol.

Sediment addition occurred through the crown of the inlet pipe, 32" (4 pipe diameters) upstream of the constructed gutter (**Figure 8**). The sediment feeder was an Auger Feeders Model VF-1 volumetric screw feeder with a 5/8" auger, spout attachment and 1.5 cubic foot hopper.

The sediment feed samples were collected by holding a 500-mL jar under the spout attachment for approximately 60 s.



Figure 8 Sediment Sampling Point

2.3 Removal Efficiency Testing

Removal Efficiency Testing was conducted in accordance with Section 5 of the NJDEP Laboratory Protocol for Filtration MTDs. Testing was completed at a flow rate of 0.0838 cfs (37.6 gpm) and a target sediment concentration of 200 mg/L.

Effluent grab samples were taken 6 times per run (at evenly spaced intervals), with each run lasting 90 minutes in duration, followed by a drain down period. In addition to the effluent samples, 3 background samples were taken with every odd-numbered effluent sample (1st, 3rd and 5th). In all cases, effluent sampling did not start until the filtration MTD had been in operation for a minimum of three detention times (13.2 minutes). When the test sediment feed was interrupted for measurement, the next effluent sample was collected following a minimum of three detention times. Sampling times for Removal Efficiency testing are summarized in **Table 3**. Effluent and background samples were collected in clean 1L wide-mouth jars.

Three sediment feed samples were collected during each run to confirm the sediment feed rate, one sample at the start of dosing, one sample in the middle of the test run and one sample just prior to the conclusion of dosing. Each sediment feed rate sample was a minimum of 100 mL and collected in a clean 500 mL jar. Sediment sampling was timed to the nearest 1/100th of a second using a calibrated stop watch and samples were weighed to the nearest 0.1 mg.

Table 3 Removal Efficiency Sampling Frequency

Sample/ Measurement Taken	Run Time (min.)								E N D	N/A	N/A
	0	15	30	45	60	75	90				
Sediment Feed	X			X			X				
Effluent		X	X	X	X	X	X				
Background		X		X			X				
Drain down										X	X

The effluent drain down samples were collected at the end of each removal efficiency run, after the pump had been switched off and the sediment feed stopped. The effluent was volumetrically quantified based on the liquid level in the BioPod™ standpipe at the end of each run. The drain down samples were taken at the same spot as the normal operation effluent samples. Two evenly spaced samples were collected to determine SSC concentration. The first volumetrically spaced sample was taken after 1/3 of the water volume had drained from the vault and the second after 2/3 of the volume had drained.

2.4 Sediment Mass Loading Capacity Testing

The Sediment Mass Loading Capacity of the BioPod™ was determined as a continuation of the Removal Efficiency Testing. All aspects of the test procedure remained the same except that the influent sediment concentration was increased from 200 to 400 mg/L. Sediment Mass Loading Capacity testing began after 15 runs of Removal Efficiency had been completed.

2.5 Scour Testing

At this time the BioPod™ Biofilter is being submitted for approval for off-line installation. Scour testing is anticipated to commence shortly and when completed scour test data will be submitted in support of on-line installation.

3. Performance Claims

Per the NJDEP verification procedure, the following are the performance claims made by Oldcastle Precast Inc. and established via the laboratory testing conducted for the BioPod™ Biofilter.

Verified Total Suspended Solids (SSC) Removal Rate

Based on the laboratory testing conducted, the BioPod™ Biofilter achieved greater than 80% removal efficiency of SSC. In accordance with the NJDEP process for obtaining approval of a stormwater treatment device from NJCAT (Procedure; NJDEP 2013) the SSC removal efficiency is rounded down to 80%.

Maximum Treatment Flow Rate (MTFR)

For the BioPod™ Biofilter tested, the MTFR was 0.0838 cfs (37.6 gpm) which corresponds to a MTFR to effective filtration treatment area ratio of 4.00×10^{-3} cfs/ft² (1.80 gpm/ft²).

Effective Filtration Treatment/Sedimentation Areas

The Effective Filtration Treatment and Sedimentation areas are the same for the BioPod™ Biofilter and will increase with increasing model size. For the BioPod™ Biofilter tested, the effective filtration treatment/sedimentation area was 20.86 ft².

Detention Time and Wet Volume

The BioPod™ Biofilter detention time and wet volume will vary with model size. The unit tested had a wet volume of 22.34 ft³ which corresponded to a detention time of 4.4 minutes at the test flow rate of 0.0838 cfs.

Sediment Mass Loading Capacity

The sedimentation mass loading capacity varies with the BioPod™ Biofilter model size. Based on the laboratory testing results, a filter with a media surface area of 20.86 ft² has a mass loading capacity of 245.0 lbs (11.74 lb/ft²).

Online/Offline Installation

At this time the BioPod™ Biofilter has only been verified for off-line installation.

Maximum Allowable Inflow Drainage Area

The laboratory testing results show that 245.0 lbs of sediment can be loaded into a 4-foot by 6-foot BioPod with internal bypass (Model # BP-46IB) while attaining a cumulative mass removal efficiency of 96.3%. Per the protocol, the maximum inflow drainage area is calculated by dividing the total sediment load observed during the test (245 lbs) by 600 lbs per acre. The result is 0.408 acres.

4. Supporting Documentation

The NJDEP Procedure (NJDEP 2013a) for obtaining verification of a stormwater manufactured treatment device (MTD) from the New Jersey Corporation for Advanced Technology (NJCAT) requires that “copies of the laboratory test reports, including all collected and measured data; all data from performance evaluation test runs; spreadsheets containing original data from all performance test runs; all pertinent calculations; etc.” be included in this section. This was discussed with NJDEP and it was agreed that as long as such documentation could be made available by NJCAT upon request that it would not be prudent or necessary to include all this information in this verification report.

4.1 Removal Efficiency

A total of 15 removal efficiency testing runs were completed in accordance with the NJDEP filter protocol. The target flow rate and influent sediment concentration were 37.6 gpm and 200 mg/L respectively. The results from all 15 runs were used to calculate the overall removal efficiency of the BioPod™ Biofilter.

Flow Rate

The flow rate was measured using a mag-type flow meter and data logger configured to take a reading every minute. For each run, the flow rate was to be maintained within 10% of the target flow with a COV (coefficient of variation) less than 0.03.

The flow data has been summarized in **Table 4**, including the compliance to the QA/QC acceptance criteria. The average flow for all removal efficiency runs was 37.5 gpm.

Sediment Addition

The target sediment concentration was 200 ± 20 mg/L with a COV less than 0.10. The sediment feed rate for each run was checked three times during each run. The average influent sediment concentration for each test flow was determined by mass balance. The amount of sediment fed into the auger feeder and the amount remaining at the end of a run was used to determine the amount of sediment fed. The sediment mass was corrected for the mass of the three feed rate samples taken during the run. The mass of the sediment fed was divided by the volume of water that flowed through the BioPod™ during dosing to determine the average influent sediment concentration for each run.

The sediment weight checks, feed rates, final concentrations and compliance to QA/QC criteria are summarized in **Table 5**.

Filter Drain Down

The BioPod™ Biofilter has a post-operation drain down feature. As per the NJDEP protocol, the amount of sediment that escapes the filter during the drain down period must be accounted for.

The volume of water in the BioPod™ was determined by:

$$\text{Water Volume} = H_W \times A_M \times f_V$$

where,

H_W = the height of the water measured in the stand pipe

A_M = the area of the media bed

f_V = the void fraction of the media bed

The two effluent samples taken during the drain down period were analysed for SSC to permit estimation of the amount of sediment that was lost. The sampling data for the drain down periods are presented in **Table 6**.

Table 4 Removal Efficiency Water Flow Rate

Run #	Runtime (min)	Water Flow Rate				QA/QC Compliance (COV < 0.03)	Max. Water Temperature (°F)
		Target (gpm)	Actual (gpm)	% Diff.	COV		
1	90	37.6	37.4	-0.54	0.004	Pass	70.9
2	90	37.6	37.8	0.51	0.004	Pass	74.3
3	90	37.6	37.5	-0.39	0.004	Pass	69.8
4	90	37.6	37.3	-0.76	0.004	Pass	72.3
5	90	37.6	37.5	-0.38	0.004	Pass	70.0
6	90	37.6	37.5	-0.32	0.004	Pass	70.0
7	90	37.6	37.6	-0.06	0.005	Pass	72.5
8	90	37.6	37.6	-0.10	0.007	Pass	70.5
9	90	37.6	37.5	-0.21	0.006	Pass	70.5
10	90	37.6	37.7	0.16	0.007	Pass	72.7
11	90	37.6	37.5	-0.21	0.005	Pass	70.5
12	90	37.6	37.7	0.20	0.008	Pass	70.3
13	90	37.6	37.5	-0.26	0.004	Pass	70.0
14	90	37.6	37.6	0.06	0.004	Pass	69.4
15	90	37.6	37.7	0.18	0.005	Pass	69.4

Table 5 Removal Efficiency Sediment Feed Rate

Run #	Run Time (min)	Weight (g)	Duration (s)	Feed Rate (g/min)	Conc.* (mg/L)	QA/QC Compliance ^Δ	Run #	Run Time (min)	Weight (g)	Duration (s)	Feed Rate (g/min)	Conc.* (mg/L)	QA/QC Compliance ^Δ
1	0	28.6192	60.35	28.453	201.4	Yes	9	0	27.1325	59.93	27.164	196.1	Yes
	45	29.6551	59.72	29.794				45	30.3139	60.19	30.218		
	90	29.1085	60.00	29.109				90	28.2427	59.97	28.257		
	COV			0.023				COV			0.054		
2	0	27.6957	59.97	27.710	201.1	Yes	10	0	29.1518	60.07	29.118	201.6	Yes
	45	28.4384	60.03	28.424				45	28.9157	59.97	28.930		
	90	28.1471	59.94	28.175				90	28.5632	60.03	28.549		
	COV			0.013				COV			0.010		
3	0	28.2203	59.81	28.310	200.6	Yes	11	0	29.6002	60.19	29.507	207.6	Yes
	45	29.6964	59.85	29.771				45	28.1232	60.06	28.095		
	90	29.3417	60.09	29.298				90	27.8065	60.03	27.793		
	COV			0.026				COV			0.032		
4	0	28.2342	60.00	28.234	201.4	Yes	12	0	31.7834	59.91	31.831	206.4	Yes
	45	28.6937	59.87	28.756				45	29.8102	59.97	29.825		
	90	28.8882	59.94	28.917				90	28.7217	59.91	28.765		
	COV			0.012				COV			0.052		
5	0	27.8267	60.00	27.827	200.0	Yes	13	0	28.9769	60.18	28.890	203.5	Yes
	45	28.9397	59.97	28.954				45	29.0209	59.84	29.098		
	90	28.3722	59.96	28.391				90	28.9804	60.13	28.918		
	COV			0.020				COV			0.004		
6	0	26.6190	59.91	26.659	200.4	Yes	14	0	27.8407	59.90	27.887	205.9	Yes
	45	27.8235	59.93	27.856				45	28.6634	60.06	28.635		
	90	28.8883	59.94	28.917				90	28.5053	60.03	28.491		
	COV			0.041				COV			0.014		
7	0	26.8762	60.00	26.876	196.1	Yes	15	0	28.9879	60.00	28.988	201.2	Yes
	45	29.2771	59.84	29.355				45	29.0011	59.94	29.030		
	90	29.3159	60.13	29.253				90	27.9057	60.06	27.878		
	COV			0.049				COV			0.023		
8	0	29.0049	59.94	29.034	196.3	Yes							
	45	29.9430	59.94	29.973									
	90	25.9761	60.06	25.950									
	COV			0.074									

* Based on sediment mass balance and average water flow rate

^Δ Average concentration 180 – 220 mg/L and COV < 0.1

Table 6 Removal Efficiency Drain Down Losses

Run #	Water Level at End of Run (inches)	Total Water Volume (L)	Average Sediment Concentration of Drain Down Samples (mg/L)	Total Sediment Lost (g)
1	14.750	195.3	2.0	0.39
2	15.500	205.2	2.8	0.56
3	15.375	203.6	3.3	0.67
4	15.000	198.6	6.0	1.18
5	15.500	205.2	5.9	1.21
6	15.500	205.2	4.7	0.96
7	15.375	203.6	4.9	0.99
8	15.750	208.6	5.2	1.08
9	15.750	208.6	5.4	1.12
10	15.750	208.6	7.3	1.52
11	15.875	210.2	7.1	1.48
12	16.125	213.5	7.5	1.60
13	16.000	211.9	7.9	1.66
14	16.250	215.2	9.1	1.95
15	16.375	216.8	9.1	1.96

Removal Efficiency Calculations

All the effluent and background samples for SSC were analysed by Good Harbour, the results have been summarized in **Table 7**.

The required background SSC concentration was < 20mg/L. The limit of quantitation for the analytical method was 2.3 mg/L. For the purposes of calculation, any result that was reported as being below the limit of quantitation (<LOQ), was assigned a value of 2 mg/L. The adjusted average sediment concentration was determined by:

$$\text{Average effluent concentration} - \text{Average background concentration}$$

Table 7 Removal Efficiency SSC Data

Run #	Suspended Sediment Concentration, SSC (mg/L)								QA/QC Compliance (background SSC < 20 mg/L)
	Run Time (min)	15	30	45	60	75	90	Average	
1	Background	2		2		2		2	YES
	Effluent	2	2	2	2	2	2.3	2.1	
2	Background	2		2		2		2	YES
	Effluent	2.5	2.8	2.6	2	2	2.6	2.4	
3	Background	2		2		2		2	YES
	Effluent	2	2.4	2.4	2.4	2.5	2.6	2.4	
4	Background	2		2		2		2	YES
	Effluent	3.3	3.1	3.0	2.9	3.1	3.4	3.1	
5	Background	2		2		2		2	YES
	Effluent	2.8	3.2	3.5	2.6	2.6	3.5	3.0	
6	Background	2		2		2		2	YES
	Effluent	3.8	3.2	2.9	3.1	3.3	3.8	3.4	
7	Background	2		2		2		2	YES
	Effluent	4.1	3.5	3.6	3.7	3.4	3.9	3.7	
8	Background	2		2		2		2	YES
	Effluent	4.9	3.9	3.9	3.2	3.5	3.5	3.8	
9	Background	2		2		2		2	YES
	Effluent	4.4	3.7	3.9	3.3	3.9	3.6	3.8	
10	Background	2		2		2		2	YES
	Effluent	5.5	4.1	4.4	3.9	4.1	3.9	4.3	
11	Background	2		2		2		2	YES
	Effluent	5.1	4.6	4.5	4.7	4.9	4.1	4.7	
12	Background	2		2		2		2	YES
	Effluent	6.7	4.2	4.4	4.2	4.1	3.9	4.6	
13	Background	2		2		2		2	YES
	Effluent	6.6	5.0	5.0	4.3	7.6	5.2	5.6	
14	Background	2		2		2		2	YES
	Effluent	6.5	5.3	5.4	5.4	4.8	5.7	5.5	
15	Background	2		2		2		2	YES
	Effluent	7.4	5.8	5.1	5.6	5.8	4.9	5.8	

The analytical results, along with the run data, were used to calculate the removal efficiency for each run, mass loading and overall removal efficiency average; the results are tabulated in **Table 8**. The removal efficiency was calculated as:

$$\text{Removal Efficiency (\%)} = \frac{\left(\frac{\text{Average Influent SS Concentration} \times \text{Total Volume of Test Water}}{\text{Average Influent SS Concentration} \times \text{Total Volume of Test Water}} \right) - \left(\frac{\text{Adjusted Effluent SS Concentration} \times \text{Total Volume of Effluent Water}}{\text{Average Influent SS Concentration} \times \text{Total Volume of Test Water}} \right) - \left(\frac{\text{Average Drain down Flow SS Concentration} \times \text{Total Volume of Drain down Water}}{\text{Average Influent SS Concentration} \times \text{Total Volume of Test Water}} \right)}{\text{Average Influent SS Concentration} \times \text{Total Volume of Test Water}} \times 100$$

Table 8 Removal Efficiency Results

Run #	Avg. Influent SSC (mg/L)	Adjusted Effluent SSC (mg/L)	Total Water Volume (L)	Average Drain Down SSC (mg/L)	Volume of Drain Down Water (L)	Run Removal Efficiency (%)	Mass of Captured Sediment (Lbs.)	Cumulative Mass Removal Efficiency (%)
1	201.4	0.1	12,453	2.0	195.3	100.0	5.526	100.0
2	201.1	0.4	12,587	2.8	205.2	99.8	5.567	99.9
3	200.6	0.4	12,477	3.3	203.6	99.8	5.506	99.8
4	201.4	1.1	12,432	6.0	198.6	99.4	5.488	99.7
5	200.0	1.0	12,477	5.9	205.2	99.4	5.470	99.7
6	200.4	1.4	12,485	4.7	205.2	99.3	5.477	99.6
7	196.1	1.7	12,516	4.9	203.6	99.1	5.363	99.5
8	196.3	1.8	12,508	5.2	208.6	99.0	5.361	99.5
9	196.1	1.8	12,492	5.4	208.6	99.1	5.349	99.4
10	201.6	2.3	12,544	7.3	208.6	98.8	5.508	99.4
11	207.6	2.7	12,495	7.1	210.2	98.7	5.645	99.3
12	206.4	2.6	12,548	7.5	213.5	98.7	5.635	99.3
13	203.5	3.6	12,494	7.9	211.9	98.2	5.505	99.2
14	205.9	3.5	12,532	9.1	215.2	98.2	5.588	99.1
15	201.2	3.8	12,546	9.1	216.8	98.1	5.458	99.0
Cumulative Mass Removal Efficiency (Runs #1-15)							99.0 %	
Captured Sediment Mass (Runs #1-15)							82.44 lbs.	

The results are typical for media bed filters in that the removal efficiency decreases as the filter bed becomes saturated with captured sediment. The cumulative mass average removal efficiency was 99.0% for the first 15 runs. During the Removal Efficiency testing, 82.44 pounds of sediment were captured in the BioPod™ Biofilter.

4.2 Sediment Mass Loading Capacity

The Sediment Mass Loading Capacity study was a continuation of the Removal Efficiency study. All aspects of the testing remained the same, except that the feed concentration was increased to 400 mg/L, up from the 200 mg/L used for the Removal Efficiency test. Additionally, the sediment feed calibration samples were used to determine sediment concentration; however this calculation was also confirmed by mass balance on a daily basis. The sediment mass loading continued until the BioPod™ Biofilter began to bypass during Run 26. The run was immediately stopped, and the flow was reduced to 90% MTRF (33.8 gpm), per the protocol. Testing continued at the lower flow rate for five more runs at which point it was decided that the desired maximum mass loading for the BioPod™ Biofilter had been reached and the Mass Loading Capacity study was terminated.

An additional 16 runs were completed for Sediment Mass Loading Capacity testing for a total of 31 runs overall. For Runs 16 – 31, the mass loading water flow rates, sediment feed rates, drain down loses, SSC data and removal efficiencies are presented in **Table 9** to **Table 13** respectively.

The total mass of sediment captured was 245.0 lbs. and the cumulative mass removal efficiency was 96.3%. The relationship between removal efficiency and sediment mass loading is illustrated in **Figure 9**.

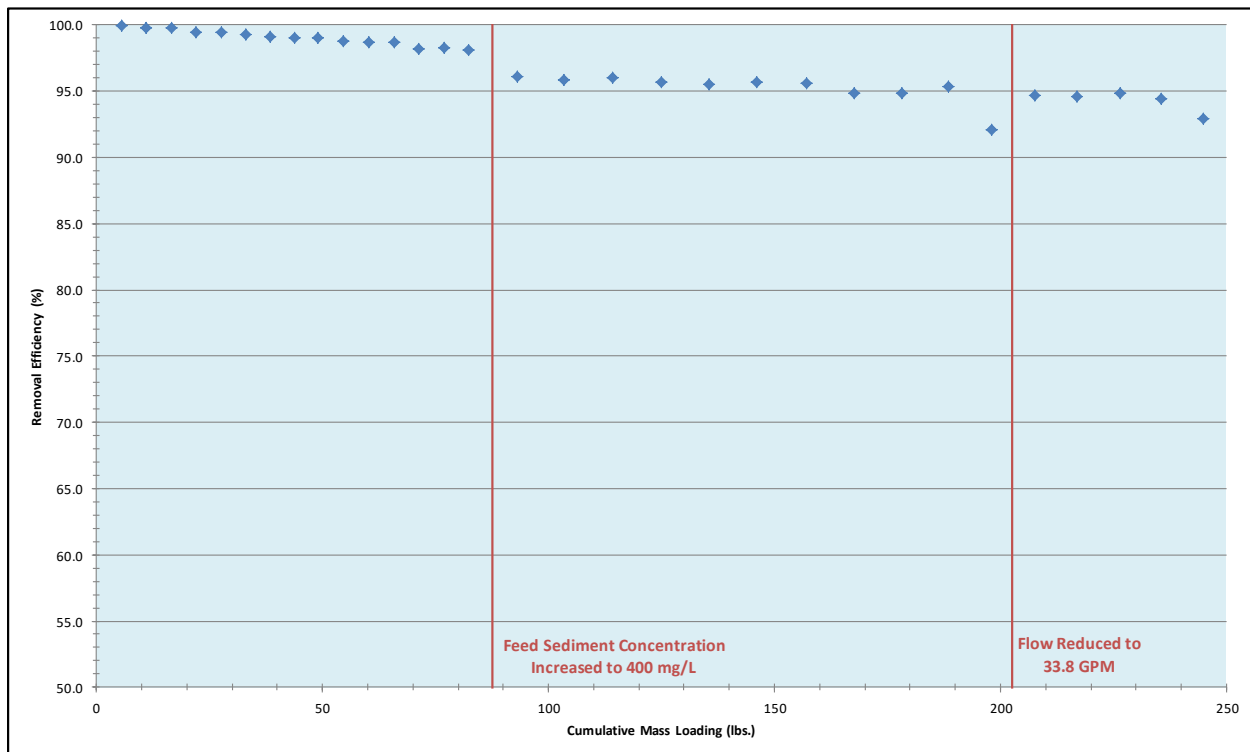

Figure 9 Removal Efficiency vs Sediment Mass Loading for the BioPod™ Biofilter

Table 9 Sediment Mass Loading Water Flow Rate

Run #	Runtime (min)	Water Flow Rate				QA/QC Compliance (COV < 0.03)	Max. Water Temperature (°F)
		Target (gpm)	Actual (gpm)	% Diff.	COV		
16	90	37.6	37.6	0.01	0.004	Pass	68.9
17	90	37.6	37.6	0.09	0.006	Pass	68.7
18	90	37.6	37.5	-0.24	0.006	Pass	68.7
19	90	37.6	37.5	-0.14	0.005	Pass	69.3
20	90	37.6	37.7	0.20	0.006	Pass	67.8
21	90	37.6	37.5	-0.30	0.004	Pass	67.8
22	90	37.6	37.5	-0.22	0.004	Pass	67.8
23	90	37.6	37.6	-0.03	0.004	Pass	68.7
24	90	37.6	37.5	-0.25	0.004	Pass	67.1
25	90	37.6	37.5	-0.15	0.005	Pass	67.1
26	85	37.6	37.4	-0.66	0.009	Pass	66.7
27	90	33.8	33.8	-0.11	0.003	Pass	68.4
28	90	33.8	33.9	0.13	0.005	Pass	66.7
29	90	33.8	33.8	-0.07	0.006	Pass	66.9
30	90	33.8	33.8	-0.26	0.006	Pass	68.9
31	90	33.8	33.8	0.00	0.004	Pass	67.1

Table 10 Sediment Mass Loading Sediment Feed Rate

Run #	Run Time (min)	Weight (g)	Duration (s)	Feed Rate (g/min)	Conc. (mg/L)	QA/QC Compliance ^Δ	Run #	Run Time (min)	Weight (g)	Duration (s)	Feed Rate (g/min)	Conc. (mg/L)	QA/QC Compliance ^Δ
16	0	56.7462	60.38	56.389	405.5	Yes	24	0	54.8869	60.00	54.887	402.4	Yes
	45	58.6093	59.94	58.668				45	56.8611	60.13	56.738		
	90	58.7475	60.63	58.137				90	59.6044	59.88	59.724		
	COV			0.021				COV			0.043		
17	0	54.6675	60.03	54.640	388.5	Yes	25	0	57.9630	59.88	58.076	398.4	Yes
	45	55.9221	60.21	55.727				45	56.5669	60.00	56.567		
	90	55.8168	60.16	55.668				90	55.0510	59.87	55.171		
	COV			0.011				COV			0.026		
18	0	55.2734	60.00	55.273	402.2	Yes	26	0	54.3011	59.93	54.365	397.0	Yes
	45	58.3436	59.87	58.470				45	53.8650	60.10	53.775		
	90	57.2288	59.66	57.555				85	57.6453	59.94	57.703		
	COV			0.029				COV			0.038		
19	0	59.2781	60.09	59.189	407.7	Yes	27	0	52.6360	59.97	52.662	405.6	Yes
	45	56.8843	59.88	56.998				45	52.9481	60.00	52.948		
	90	57.7888	60.12	57.673				90	50.1675	60.09	50.092		
	COV			0.019				COV			0.030		
20	0	56.1630	59.63	56.511	401.3	Yes	28	0	50.5701	60.06	50.520	395.9	Yes
	45	56.5331	59.72	56.798				45	50.4133	59.94	50.464		
	90	58.2489	59.90	58.346				90	51.4454	60.06	51.394		
	COV			0.017				COV			0.010		
21	0	57.5590	59.91	57.645	403.9	Yes	29	0	52.9891	60.00	52.989	404.8	Yes
	45	56.5018	59.94	56.558				45	50.5817	60.12	50.481		
	90	57.7074	60.00	57.707				90	51.8366	59.81	52.001		
	COV			0.011				COV			0.024		
22	0	57.8840	59.97	57.913	414.1	Yes	30	0	48.9575	60.03	48.933	396.2	Yes
	45	58.9439	59.59	59.349				45	48.6612	60.19	48.508		
	90	59.2138	60.09	59.125				90	54.4859	60.07	54.422		
	COV			0.013				COV			0.065		
23	0	56.0015	59.47	56.501	403.7	Yes	31	0	53.9859	60.03	53.959	402.3	Yes
	45	58.4615	60.06	58.403				45	48.1257	59.90	48.206		
	90	57.4301	60.00	57.430				90	52.3717	59.93	52.433		
	COV			0.017				COV			0.058		

^Δ Average concentration 360 – 440 mg/L and COV < 0.1

Table 11 Sediment Mass Loading Drain Down Losses

Run #	Water Level at End of Run (inches)	Total Water Volume (L)	Average Sediment Concentration of Drain Down Samples (mg/L)	Total Sediment Lost (g)
16	16.375	216.8	22.8	4.93
17	17.250	228.4	23.2	5.30
18	17.000	225.1	22.0	4.94
19	16.625	220.1	29.0	6.37
20	18.875	249.9	26.3	6.57
21	18.125	240.0	25.4	6.10
22	18.500	245.0	24.3	5.94
23	18.625	246.6	19.7	4.86
24	18.625	246.6	19.3	4.75
25	18.750	248.3	25.8	6.39
26	20.000	264.8	34.1	9.02
27	14.250	192.0	40.7	7.81
28	16.000	211.9	33.2	7.02
29	16.000	211.9	41.5	8.78
30	14.750	195.3	51.9	10.13
31	17.375	230.1	39.6	9.11

Table 12 Sediment Mass Loading SSC Data

Run #	Suspended Sediment Concentration, SSC (mg/L)								QA/QC Compliance (background SSC < 20 mg/L)
	Run Time (min)	15	30	45	60	75	90	Average	
16	Background	2		2		2		2	YES
	Effluent	19.4	17.8	17.5	17.1	17.3	17.2	17.7	
17	Background	2		2		2		2	YES
	Effluent	20.4	18.2	17.4	18.1	17.2	15.9	17.9	
18	Background	2		2		2		2	YES
	Effluent	20.9	18.5	17.2	18.3	17.3	16.3	18.1	
19	Background	2		2		2		2	YES
	Effluent	23.7	16.8	17.1	17.3	16.7	25.7	19.6	
20	Background	2		2		2		2	YES
	Effluent	24.8	20.5	20.2	18.4	18.8	17.0	20.0	
21	Background	2		2		2		2	YES
	Effluent	25.9	19.3	18.7	18.1	17.1	17.2	17.4	
22	Background	2		2		2.3		2.1	YES
	Effluent	24.7	20.5	16.8	20.7	19.8	19.7	20.4	
23	Background	2		2		2		2	YES
	Effluent	32.8	23.1	21.6	21.3	19.2	19.7	23.0	
24	Background	2.4		2		2		2.1	YES
	Effluent	29.4	23.1	22.5	21.1	20.8	20.7	22.9	
25	Background	2.7		2.8		3.1		2.9	YES
	Effluent	26.9	22.0	20.7	20.9	19.3	18.9	21.5	
26	Background	4.5		2.9		2		2.9	YES
	Effluent	38.1	39.4	33.3	31.9	31.3	30.9	34.2	
27	Background	2.6		2		2		2.2	YES
	Effluent	28.5	23.4	23.4	22.5	22.0	21.2	23.5	
28	Background	2		2		2		2	YES
	Effluent	28.2	23.6	20.6	22.8	22.0	21.5	23.1	
29	Background	2		2		2		2	YES
	Effluent	29.4	21.9	20.0	20.8	21.5	21.7	22.6	
30	Background	2		2		2		2	YES
	Effluent	29.1	21.7	22.7	19.9	23.9	23.6	23.5	
31	Background	2		2		2		2	YES
	Effluent	35.5	30.2	27.9	29.2	29.3	29.4	30.3	

Table 13 Sediment Mass Loading Removal Efficiency Results

Run #	Avg. Influent SSC (mg/L)	Adjusted Effluent SSC (mg/L)	Total Water Volume (L)	Average Drain Down SSC (mg/L)	Volume of Drain Down Water (L)	Run Removal Efficiency (%)	Mass of Captured Sediment (Lbs.)	Cumulative Mass Removal Efficiency (%)
16	405.5	15.7	12,528	22.8	216.8	96.1	10.76	98.7
17	388.5	15.9	12,534	23.2	228.4	95.9	10.29	98.4
18	402.2	16.1	12,495	22.0	225.1	96.0	10.63	98.2
19	407.7	17.6	12,508	29.0	220.1	95.6	10.75	97.9
20	401.3	18.0	12,548	26.3	249.9	95.5	10.60	97.7
21	403.9	17.5	12,485	25.4	240.0	95.7	10.63	97.6
22	414.1	18.2	12,495	24.3	245.0	95.6	10.90	97.5
23	403.7	21.0	12,521	19.7	246.6	94.8	10.57	97.3
24	402.4	20.8	12,491	19.3	246.6	94.8	10.51	97.1
25	398.4	18.6	12,504	25.8	248.3	95.3	10.47	97.0
26	397.0	31.2	11,735	34.1	264.8	92.1	9.462	96.8
27	405.6	21.4	11,261	40.7	192.0	94.7	9.531	96.7
28	395.9	21.1	11,289	33.2	211.9	94.6	9.323	96.6
29	404.8	20.6	11,267	41.5	211.9	94.8	9.534	96.5
30	396.2	21.5	11,243	51.9	195.3	94.4	9.275	96.4
31	402.3	28.3	11,273	39.6	230.1	92.9	9.290	96.3
Cumulative Mass Removal Efficiency (Runs 1 – 31):						96.3 %		
Captured Sediment Mass (Runs 1 – 31):						245.0 lbs.		

4.3 Filter Driving Head

The water level in the BioPod™ Biofilter, as measured from the inserted slotted pipe, has been tabulated in **Table 6** and **Table 11**. **Figure 10** illustrates the increase in water level inside the filter as sediment is captured.

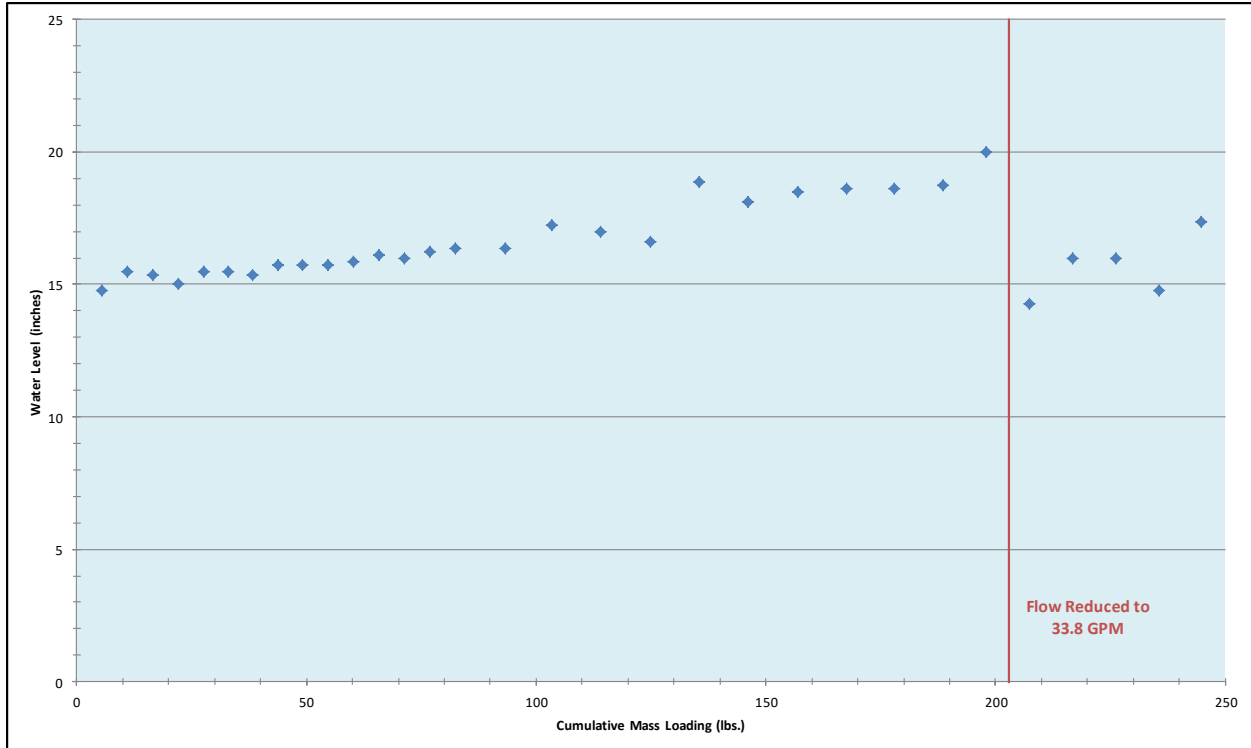

Figure 10 Increase in Driving Head vs Sediment Mass Load

5. Design Limitations

Required Soil Characteristics

The BioPod™ is suitable for installation in all soil types.

Slope

The BioPod™ is typically recommended for installation with no slope to ensure proper, consistent operation. Often, the top piece can be installed to meet finished grade. Steep slopes should be reviewed by Oldcastle engineering support.

Maximum Flow Rate

The maximum flow rate for the BioPod™ is 1.8 gpm/ft² of media surface area.

Allowable Head Loss

There is an operational head loss associated with each BioPod™ device. The head loss will increase over time due to increased sediment loading. When configured with an internal bypass a designed head loss of 31.5” should be used. Site specific treatment flow rates, peak flow rates,

pipe diameters and pipe slopes are evaluated to ensure there is appropriate head for the system to function properly.

Maintenance Requirements

For all successful stormwater quality control systems, effective performance requires regular and proper maintenance. Maintenance frequency and requirements are dependent on the conditions and pollutant loading of each site. In general, it is recommended that inspections and/or maintenance be conducted on a regularly occurring basis to ensure continued functionality of the system. Maintenance activities could also be required in the case of an extreme rainfall event, chemical spill or heavier than anticipated pollutant loading.

Installation Limitations

The BioPod™ has few installation limitations. The BioPod™ is typically delivered to the site with all internal components, including the StormMix media, installed. The contractor is then responsible for installation of the system following any requirements that would apply for any precast concrete structure. This typically includes: preparing the appropriate excavation and base layer; providing and using the appropriate lifting equipment to unload and set the BioPod™ vault components; providing and connecting the inlet and outlet piping; and following the construction plans for selection of backfill material and placement. The contractor is also responsible for protecting the BioPod™ from construction runoff until site construction is complete. Oldcastle Precast provides full-service technical design support throughout the life of a project.

Configurations

The BioPod™ is available in multiple configurations, including internal and external bypass configurations allowing it to be installed online or offline. The BioPod™ can be installed above, at, or below grade and comes in a variety of precast concrete sizes, allowing maximum design flexibility.

Structural Load Limitations

The BioPod™ structure is typically located adjacent to a roadway and therefore the precast base is designed to handle H-20 traffic loads. For deeper installations or installations requiring a greater load capacity the system will be designed and manufactured to meet those requirements. Oldcastle provides full-service technical design support throughout the life of a project and can help ensure the system is designed for the appropriate structural load requirements.

Pre-treatment Requirements

The BioPod™ does not require additional pre-treatment.

Limitations in Tailwater

Tailwater conditions may impact the amount of driving head available to the BioPod™ and thus may impact the operation and/or lifecycle of the system. Specific project conditions should be assessed as part of the design process.

Depth to Seasonal High-Water Table

The operation of the BioPod™ is typically not impacted by the seasonal high-water table. However, the high-water table may impact the buoyancy of the concrete vault. Specific project conditions should be assessed as part of the design process.

6. Maintenance Plans

Maintenance Overview

State and local regulations require all stormwater management systems to be inspected on a regular basis and maintained as necessary to ensure performance and protect downstream receiving waters. Without maintenance, excessive pollutant buildup can limit system performance by reducing the operating capacity and increasing the potential for scouring of pollutants during periods of high flow.

The BioPod™ may require periodic irrigation to establish and maintain vegetation. Vegetation will typically become established about two years after planting. Irrigation requirements are ultimately dependent on climate, rainfall, and the type of vegetation selected. The BioPod™ Inspection & Maintenance Manual is available at: https://oldcastleprecast-yut3re1sojoa.netdna-ssl.com/wp-content/uploads/OSS_BioPod_InspMaint_Jan-2018.pdf

Inspection Equipment

The following equipment is helpful when conducting BioPod™ inspections:

- Recording device (pen and paper form, voice recorder, iPad, etc.)
- Suitable clothing (appropriate footwear, gloves, hardhat, safety glasses, etc.)
- Traffic control equipment (cones, barricades, signage, flagging, etc.)
- Manhole hook or pry bar
- Flashlight
- Tape measure

Inspection Procedures

BioPod™ inspections are visual and are conducted without entering the unit. To complete an inspection, safety measures including traffic control should be deployed before the access covers or tree grates are removed. Once the covers have been removed, the following items should be

checked and recorded (see form provided on page 6 of the O&M Manual) to determine whether maintenance is required:

- If the BioPod™ is equipped with an internal bypass, inspect the contoured inlet rack and outlet chamber and note whether there are any broken or missing parts. In the unlikely event that internal parts are broken or missing, contact Oldcastle Stormwater at (800) 579-8819 to determine appropriate corrective action.
- Note whether the curb inlet, inlet pipe, or, if the unit is equipped with an internal bypass, the inlet rack is blocked or obstructed.
- If the unit is equipped with an internal bypass, observe, quantify, and record the accumulation of trash and debris in the inlet rack. The significance of accumulated trash and debris is a matter of judgment. Often, much of the trash and debris may be removed manually at the time of inspection if a separate maintenance visit is not yet warranted.
- If it has not rained within the past 24 hours, note whether standing water is observed in the BioPod™ chamber.
- Finally, observe, quantify, and record presence of invasive vegetation and the amount of trash and debris and sediment load in the chamber. Erosion of the mulch and filter media bed should also be recorded. Sediment load may be rated light, medium, or heavy depending on the conditions. Loading characteristics may be determined as follows:
 - Light sediment load – sediment is difficult to distinguish among the mulch fibers at the top of the mulch layer; the mulch appears almost new.
 - Medium sediment load – sediment accumulation is apparent and may be concentrated in some areas; probing the mulch layer reveals lighter sediment loads under the top 1” of mulch.
 - Heavy sediment load – sediment is readily apparent across the entire top of the mulch layer; individual mulch fibers are difficult to distinguish; probing the mulch layer reveals heavy sediment load under the top 1” of mulch.

Often, much of the invasive vegetation and trash and debris may be removed manually at the time of inspection if a separate maintenance visit is not yet warranted.

Maintenance Indicators

Maintenance should be scheduled if any of the following conditions are identified during inspection:

- The concrete structure is damaged, or the tree grate or access cover is damaged or missing.
- The curb inlet or inlet rack is obstructed.
- Standing water is observed in the BioPod™ chamber more than 24 hours after a rainfall event (use discretion if the BioPod™ is located downstream of a storage system that attenuates flow).
- Trash and debris in the inlet rack cannot be easily removed at the time of inspection.
- Trash and debris, invasive vegetation, or sediment load in the BioPod™ chamber is heavy or excessive erosion has occurred.

Maintenance Equipment

The following equipment is helpful when conducting BioPod™ maintenance:

- Suitable clothing (appropriate footwear, gloves, hardhat, safety glasses, etc.)
- Traffic control equipment (cones, barricades, signage, flagging, etc.)
- Manhole hook or pry bar
- Flashlight
- Tape measure
- Rake, hoe, shovel and broom
- Bucket
- Pruners
- Vacuum truck (optional)

Maintenance Procedures

Maintenance should be conducted during dry weather when no flow is entering the system. All maintenance may be conducted without entering the BioPod™ structure. Once safety measures such as traffic control are deployed, the access covers may be removed, and the following activities may be conducted to complete maintenance:

- Remove all trash and debris from the curb inlet and inlet rack manually or by using a vacuum truck as required.
- Remove all trash and debris and invasive vegetation from the BioPod™ chamber manually or by using a vacuum truck as required.
- If the sediment load is medium or light but erosion of the filter media bed is evident, redistribute the mulch with a rake or replace missing mulch as appropriate. If erosion persists, rocks may be placed in the eroded area to help dissipate energy and prevent recurring erosion.
- If the sediment load is heavy, remove the mulch layer using a hoe, rake, shovel, and bucket, or by using a vacuum truck as required. If the sediment load is particularly heavy, inspect the surface of the StormMix media once the mulch has been removed. If the media appears clogged with sediment, remove and replace one or two inches of StormMix media prior to replacing the mulch layer.
- Prune vegetation as appropriate and replace damaged or dead plants as required.
- Replace the tree grate and/or access covers and sweep the area around the BioPod™ to leave the site clean.
- All material removed from the BioPod™ during maintenance must be disposed of in accordance with local regulations. In most cases, the material may be handled in the same manner as disposal of material removed from sump catch basins or manholes.

Natural, shredded hardwood mulch should be used in the BioPod™. Timely replacement of the mulch layer according to the maintenance indicators described above should protect the StormMix media below the mulch layer from clogging due to sediment accumulation. However, whenever the mulch is replaced, the BioPod™ should be visited 24 hours after the next major storm event to

ensure that there is no standing water in the chamber. Standing water indicates that the StormMix media below the mulch layer is clogged and must be replaced. Please contact Oldcastle Stormwater at (800) 579-8819 to purchase StormMix media.

7. Statements

The following attached pages are signed statements from the manufacturer (Oldcastle Precast Inc.), the independent test laboratory (Good Harbour Labs), and NJCAT. These statements are a requirement of the verification process.

In addition, it should be noted that this report has been subjected to public review (e.g. stormwater industry) and all comments and concerns have been satisfactorily addressed.



January 24, 2018

Dr. Richard S. Magee, Sc.D., P.E., BCEE
NJCAT
Center for Environmental Systems
Stevens Institute of Technology
Castle Point on Hudson
Hoboken, NJ 07030-0000

Dr. Magee,

Oldcastle is pleased to provide this letter as our statement certifying that the protocol "New Jersey Department of Environmental Protection Laboratory Protocol to Assess Total Suspended Solids Removal by a Filtration Manufactured Treatment Device" (NJDEP Filter Protocol, January 25, 2013) was strictly followed while testing our BioPod™ Biofilter with StormMix Media™. The testing was performed at Good Harbour Laboratories located in Mississauga, Ontario Canada. All data pertaining to the BioPod NJDEP Protocol test is included in the Verification Report.

Sincerely,

A handwritten signature in blue ink that reads "Chris Demarest". The signature is written in a cursive, flowing style.

Chris Demarest
Product Development Manager
Oldcastle Precast



January 24, 2018

Dr. Richard Magee, ScD., P.E., BCEE
Executive Director
New Jersey Corporation for Advanced Technology (NJCAT)

Re: Performance Verification of the Oldcastle BioPod™ Biofilter with StormMix Media™

Dear Dr. Magee,

Good Harbour Laboratories was contracted by Oldcastle Precast Inc. to conduct performance testing of their 4' x 6' BioPod™ Biofilter in accordance with New Jersey Department of Environmental Protection Laboratory Protocol to Assess Total Suspended Solids Removal by a Filtration Manufactured Treatment Device (January, 2013).

Good Harbour Laboratories is an independent hydraulic test facility located in Mississauga, Ontario Canada. I certify that we evaluated the 4' x 6' BioPod™ Biofilter during the month of October 2017 according to the aforementioned test protocol. The results presented in the NJCAT Verification Report dated January, 2018 are accurate and all procedures and requirements stated in the test protocol were met or exceeded. I confirm that all test data that was collected is included or referenced in the report.

GHL provides testing and verification services for numerous water treatment technologies including stormwater treatment devices. GHL has had several different stormwater equipment manufacturers as clients and we have accumulated considerable experience in testing these devices. In order to be able to make this experience available to as many potential clients as possible, GHL is careful to maintain its position as an independent service provider.

With the above in mind I, the undersigned, on behalf of GHL and Monteco, confirm:

- that I do not have any conflict of interest in connection to the contracted testing;
- that I will inform NJCAT, without delay, of any situation constituting a conflict of interest or potentially giving rise to a conflict of interest;



Good Harbour Laboratories
T: 905.696.7276 | F: 905.696.7279
A: 2596 Dunwin Drive, Mississauga, ON L5L 1J5
www.goodharbourlabs.com



-that I have not granted, sought, attempted to obtain or accepted and will not grant, seek, attempt to obtain, or accept any advantage, financial or in kind, to or from any party whatsoever, constituting an illegal or corrupt practice, either directly or indirectly, as an incentive or reward relating to the outcome of the testing.

Sincerely,

Date

A handwritten signature in blue ink that reads "Greg Williams".

A handwritten date in blue ink that reads "Jan. 24/18".

Dr. Greg Williams, P.Eng.
Managing Director
Good Harbour Laboratories

CC: Chris Demarest, Oldcastle Precast

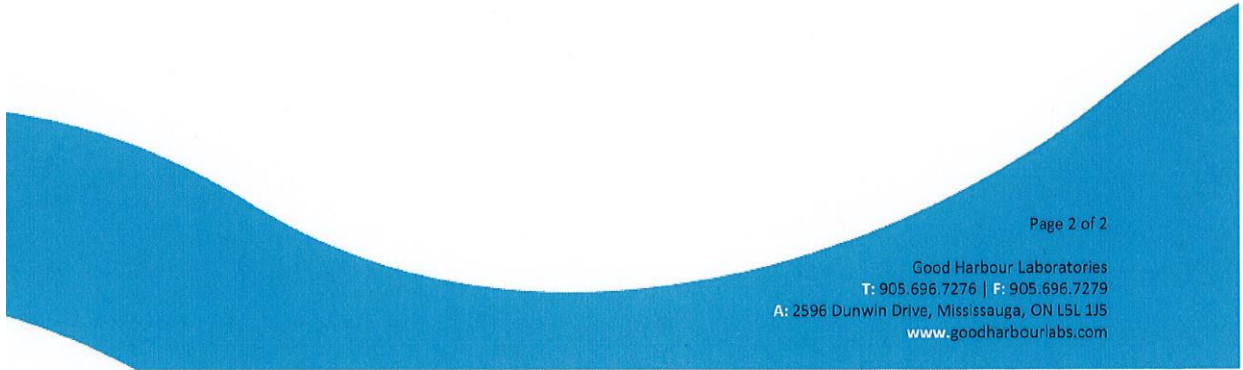



**Center for Environmental Systems
Stevens Institute of Technology
One Castle Point
Hoboken, NJ 07030-0000**

January 23, 2018

Jim Murphy, Chief
NJDEP
Bureau of Non-Point Pollution Control
Division of Water Quality
401 E. State Street
Mail Code 401-02B, PO Box 420
Trenton, NJ 08625-0420

Dear Mr. Murphy,

Based on my review, evaluation and assessment of the testing conducted on the Oldcastle Precast BioPod™ Biofilter with StormMix Media™ by Good Harbour Laboratories (GHL) at their site in Mississauga, Ontario, Canada, the test protocol requirements contained in the “*New Jersey Department of Environmental Protection Laboratory Protocol to Assess Total Suspended Solids Removal by a Filtration Manufactured Treatment Device*” (NJDEP Filter Protocol, January 2013) were met or exceeded. Specifically:

Test Sediment Feed

The test sediment used for the removal efficiency study was custom blended by GHL using various commercially available silica sands. Three samples of sediment were sent out for particle size analysis using the methodology of ASTM method D422-63. The testing lab was Maxxam Analytics, an independent test lab also located in Mississauga, Ontario Canada. The sediment was found to meet the NJDEP particle size specification, had a d_{50} of 69 microns, and was acceptable for use.

Removal Efficiency Testing

Thirty-one (31) removal efficiency testing runs were completed in accordance with the NJDEP test protocol. Fifteen (15) of the 31 test runs were conducted during removal efficiency testing and sixteen (16) during mass loading capacity testing. The target flow rate and influent sediment

concentration during RE testing were 37.6 gpm and 200 mg/L. The overall average removal efficiency was 99.0% for the 15 runs.

Sediment Mass Loading Capacity

Mass loading capacity testing was conducted as a continuation of removal efficiency (RE) testing. Mass loading test runs were conducted using identical testing procedures and targets as those used in the RE runs, the only change was to increase the target influent concentration to 400 mg/L after test run 15. The BioPod™ Biofilter began to bypass during run 26. The run was immediately stopped, and the flow was reduced to 90% MTFR (33.8 gpm), per the protocol. Testing continued at the lower flow rate for five more runs at which point it was decided that the desired maximum mass loading for the BioPod™ Biofilter had been reached and the Mass Loading Capacity study was terminated. The total mass captured by the BioPod™ Biofilter during the removal efficiency and sediment mass loading capacity testing was 245 lbs. This is equivalent to a sediment mass loading capacity of 11.74 lb/ft² of effective filtration treatment area.

No maintenance was performed on the test system during the entire testing program.

Sincerely,



Richard S. Magee, Sc.D., P.E., BCEE

8. References

1. Good Harbour Laboratories, *Laboratory Performance Testing Quality Assurance Project Plan (QAPP) for the Oldcastle TreePod™ Biofilter in Accordance with the NJDEP Laboratory Testing Protocol (2013)*. Prepared by Good Harbour Laboratories, June 2017.
2. Good Harbour Laboratories Notebook A019, pp. 69-87; Notebook A020, pp. 15-30.
3. NJDEP 2013a. *New Jersey Department of Environmental Protection Procedure for Obtaining Verification of a Stormwater Manufactured Treatment Device from New Jersey Corporation for Advanced Technology*. January 25, 2013.
4. NJDEP 2013b. *New Jersey Department of Environmental Protection Laboratory Protocol to Assess Total Suspended Solids Removal by a Filtration Manufactured Treatment Device*. January 25, 2013.

VERIFICATION APPENDIX

Introduction

- Manufacture: Oldcastle Precast, Inc., Longe Street, Suite 100, Stockton, CA 95206.
Website: <https://oldcastleprecast.com/> Phone: 925-667-7100
- MTD - BioPod™ Biofilter System with StormMix Media™ verified systems are shown in **Table A-1**
- TSS Removal Rate – 80%
- Off-line installation

Detailed Specification

- BioPod™ Biofilter model sizes and New Jersey treatment capacities are attached (**Table A-1**).
- Maximum inflow drainage area is also shown on **Table A-1**.
- The depth of the StormMix Media™ in the BioPod™ Biofilter is 18 inches.
- The BioPod™ Biofilter is designed to drain down in approximately 13 minutes.
- The minimum driving head required for a standard BioPod™ Biofilter is 25.5”. The maximum head prior to bypass is 31.5”. Contact Oldcastle Precast’s Solutions Engineering Department for project specific questions.
- The BioPod™ Biofilter System with StormMix™ Installation and Maintenance Manual can be found at: https://oldcastleprecast-yut3re1sojoa.netdna-ssl.com/wp-content/uploads/OSS_BioPod_InspMaint_Jan-2018.pdf
- This certification does not extend to the enhanced removal rates under N.J.A.C. 7:8-5.5 through the addition of settling chamber (such as a hydrodynamic separator) or a media filter (such as a sand filter) to achieve an enhanced TSS removal rate.

Table A-1 BioPod™ Biofilter Model Sizes and New Jersey Treatment Capacities

Configuration	Dimensions (ft)	Media Surface Area¹ (ft²)	Effective Sedimentation Area¹ (ft²)	Effective Filtration Treatment Area¹ (ft²)	MTFR² (cfs)	Drainage Area³ (acres)
BioPod	4 x 4	16	16	16	0.064	0.31
	4 x 6	24	24	24	0.096	0.47
	4 x 8	32	32	32	0.128	0.63
	4 x 12	48	48	48	0.192	0.94
	6 x 6	36	36	36	0.144	0.70
	6 x 8	48	48	48	0.192	0.94
	6 x 12	72	72	72	0.288	1.41
	8 x 16	128	128	128	0.512	2.50
BioPod with Internal Bypass	4 x 6	20.86	20.86	20.86	0.083	0.41
	4 x 8	28.86	28.86	28.86	0.115	0.56
	4 x 12	44.86	44.86	44.86	0.179	0.88
	6 x 6	32.86	32.86	32.86	0.131	0.64
	6 x 8	44.86	44.86	44.86	0.179	0.88
	6 x 10	56.86	56.86	56.86	0.227	1.11
	6 x 12	68.86	68.86	68.86	0.275	1.35
	8 x 16	124.86	124.86	124.86	0.499	2.44
<p>1. Since the treatment system is a horizontal filter, media surface area (MSA) equals effective sedimentation area (ESA) equals effective filtration treatment area (EFTA).</p> <p>2. MTFR is based on 1.8 gpm/ft² (0.004 cfs/ft²) of effective filtration treatment area.</p> <p>3. Drainage area is based on 11.74 lb./ft² (245 lb./20.86 ft²) of effective filtration treatment area and the equation in the NJDEP Filtration Protocol Appendix, where drainage area is calculated based on 600 lbs. of mass contributed per acre of drainage area annually.</p>						